

# PANEL FRAME MOUNTING INSTRUCTIONS

## Kit Includes:

- Panel Frame
- Brass Inserts  
6-32 X 1/4 Thread (M3.5 x 6.3mm)  
4-40 X 1/4 (M3 x 6.3mm)  
(1120, 1150 only)
- Mounting Screws
- O-Ring (Panel Seal)
- Instruction Sheet

BRASS  
INSERTS

PANEL FRAME

MOUNTING  
SCREWS

O-RING

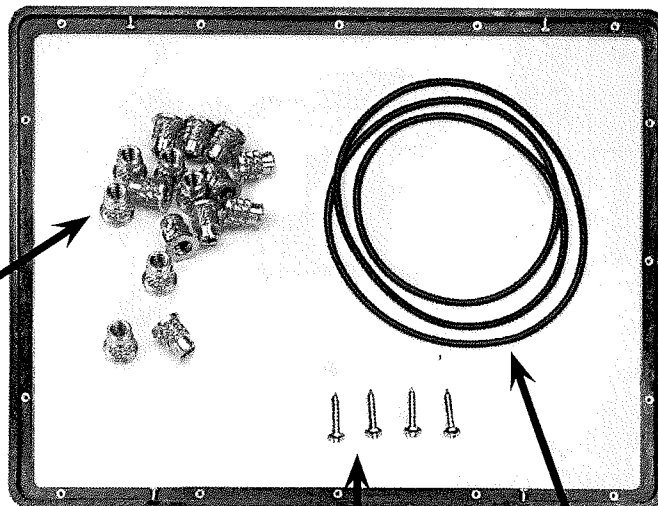

1. The frame must be correctly oriented prior to installation. Check for the model identifier and the word "front" (i.e. 1450 front). The frame is to be installed with these characters closest to the front of the case. (If the frame is installed in reverse, the mounting screws will protrude through the case as they are oriented to match the external ribs).
2. To install the brass inserts, place the frame face down (model identifier facing down, see step 1). Place the non-shoulder small end of the insert into the hole and push in with a Phillips screwdriver until fully seated on the shoulder.
3. To secure the frame to the case, install the frame into the case until fully seated on the internal ribs. Next, insert a mounting screw (supplied with kit) into the hole and press firmly as you turn the screwdriver to start self-tapping. Continue to turn until fully seated or use a 90° drill motor.
4. Install the o-ring into the channel between the frame and the case. The o-ring must be fully seated. Install your custom panel. Your panel should completely cover the o-ring for maximum fluid and dust resistance. Install the screws (into brass inserts) by hand, DO NOT APPLY PRESSURE. The fit of the insert to frame was designed for easy installation without specialized tools (by hand). Excess pressure will push the brass inserts back out the other side.

**PROTECTOR CASES**

**23215 Early Avenue, Torrance, California 90505**

REVISIONS		
REV.	DESCRIPTION	DATE
PR	PRODUCTION RELEASE SEE ECO 06-030	2/24/2006
		APPR'VD BT

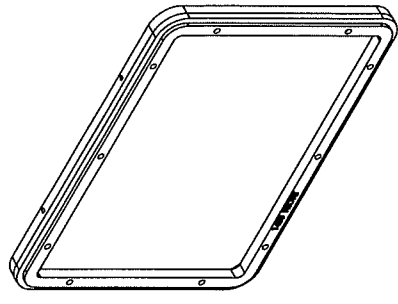
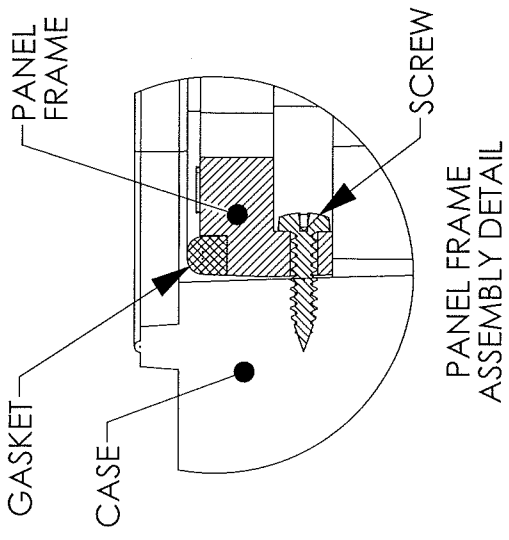
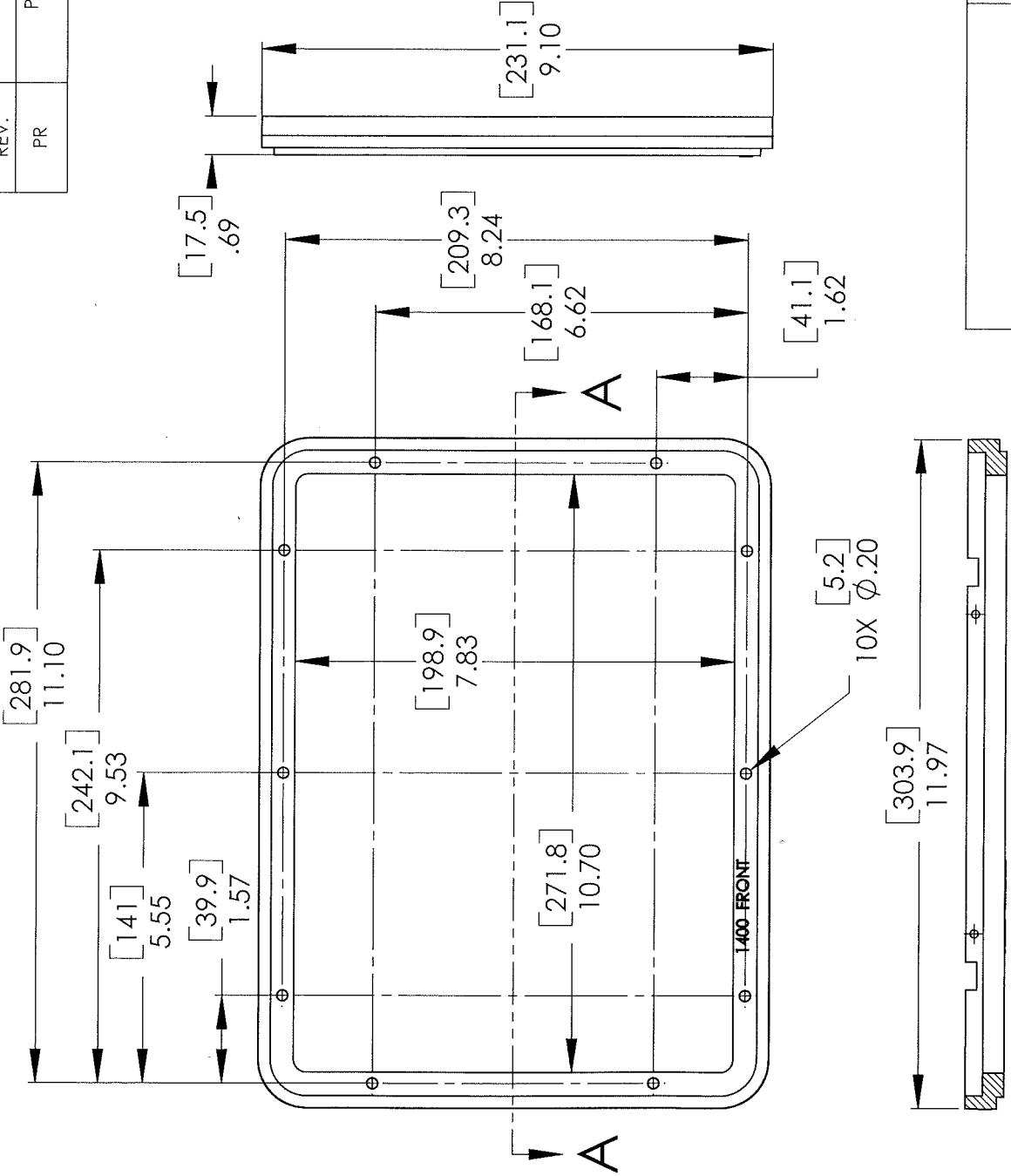

TITLE		APPROVALS		DATE	
1400 PANEL FRAME INSTRUCTION SHEET		DRAWN	CHECK	APPR	
DO NOT SCALE DRAWING		DRAWG # 1403-314-000		REV	PR
SIZE A	MATERIAL 1 OF 1	SCALE			

1. DIMENSIONS IN [ ] ARE IN MILLIMETERS  
 NOTES: UNLESS OTHERWISE SPECIFIED.

SECTION A-A

## PE PANEL FRAME O-RING INSTALLATION

## INSTALACIÓN DE LA ANILLO DE SELLADO DE NEOPRENO ANILLO DE ADAPTACIÓN EN FORMA DE D

## INSTALLATION DU JOINT TORIQUE DU SUPPORT PLATINE EN FORME DE D

## INSTALLATION DES D-FÖRMIGEN EINBAURAHMEN

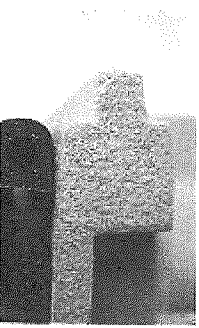

- 1.** Lay the flat side down along the case wall.

Disponga el lado plano a lo largo de la pared de la maleta.

Poser le côté plat le long de la paroi de la valise.

Legen Sie die flache Seite entlang der Kofferwand.

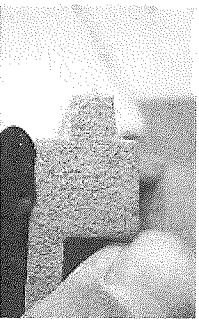

- 2.** Squeeze and push the flat face of the o-ring into the o-ring channel.

Apriete y empuje la cara plana del anillo de sellado de neopreno hacia el interior del canal del anillo de sellado de neopreno.

Appuyer et pousser sur la face plate du joint torique pour le faire rentrer dans le canal du joint torique.

Drücken und schieben Sie die flache Seite des O-Rings in den O-Ring Kanal.

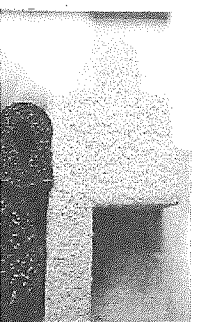

- 3.** Fully install the o-ring.

Acabe de colocar el anillo de sellado de neopreno.

Installer totalement le joint torique.

Installieren Sie den O-Ring vollständig.

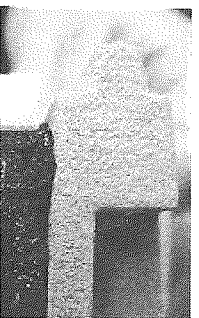

- 4.** Install custom panel frame.

Coloque el panel de adaptación a medida.

Installer le support de platine personnalisé.

Installieren Sie den passenden Einbaurahmen